

# WEINBRIDGE OSCILLATOR

## THEORY :

Weinbridge oscillator is one of the most popular type of oscillators used in audio and sub audio frequency ranges (20-22KHZ). This type of oscillator is simple in design, compact in size and remarkably stable in its frequency output. Its output is relatively free from distortion and its frequency can be varied easily. However, the maximum frequency output of a typical weinbridge oscillator is only about 1MHZ. This is also, in fact, a phase shift oscillator. It employs two transistors, each producing a phase shift of 180 degree and thus producing a total phase shift of 360 or 0 degree.

## SCHEMATIC DIAGRAM:

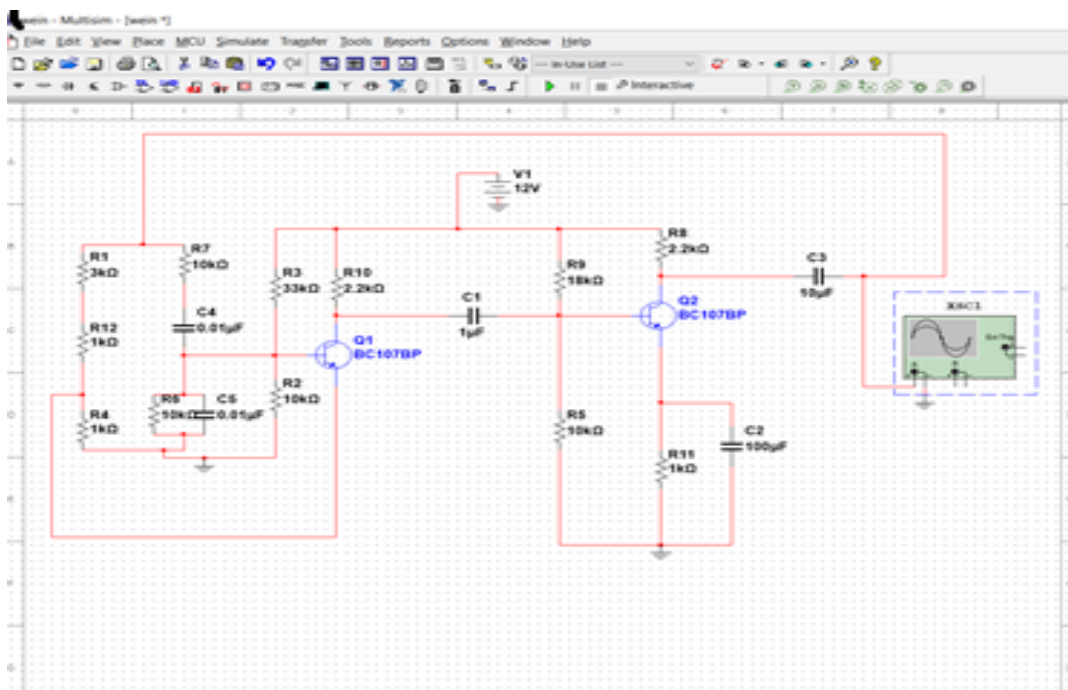

## OUTPUT:

