

Title of the experiment:

Analysis of frequency response of the BJT amplifier using eSim.

Theory:

Frequency Response of BJT allows us to see exactly how the output gain (known as the magnitude response) and the phase (known as the phase response) changes at a particular single frequency, or over a whole range of different frequencies. The range of frequencies can be from 0Hz, (d.c.) to many thousands of mega-hertz, (MHz) depending upon the design characteristics of the circuit. The frequency response analysis of BJT is shown by plotting its gain, using logarithmic frequency scale along the x-axis.

Schematic Diagram:

The circuit schematic of the BJT amplifier for frequency response in eSim is as shown below:

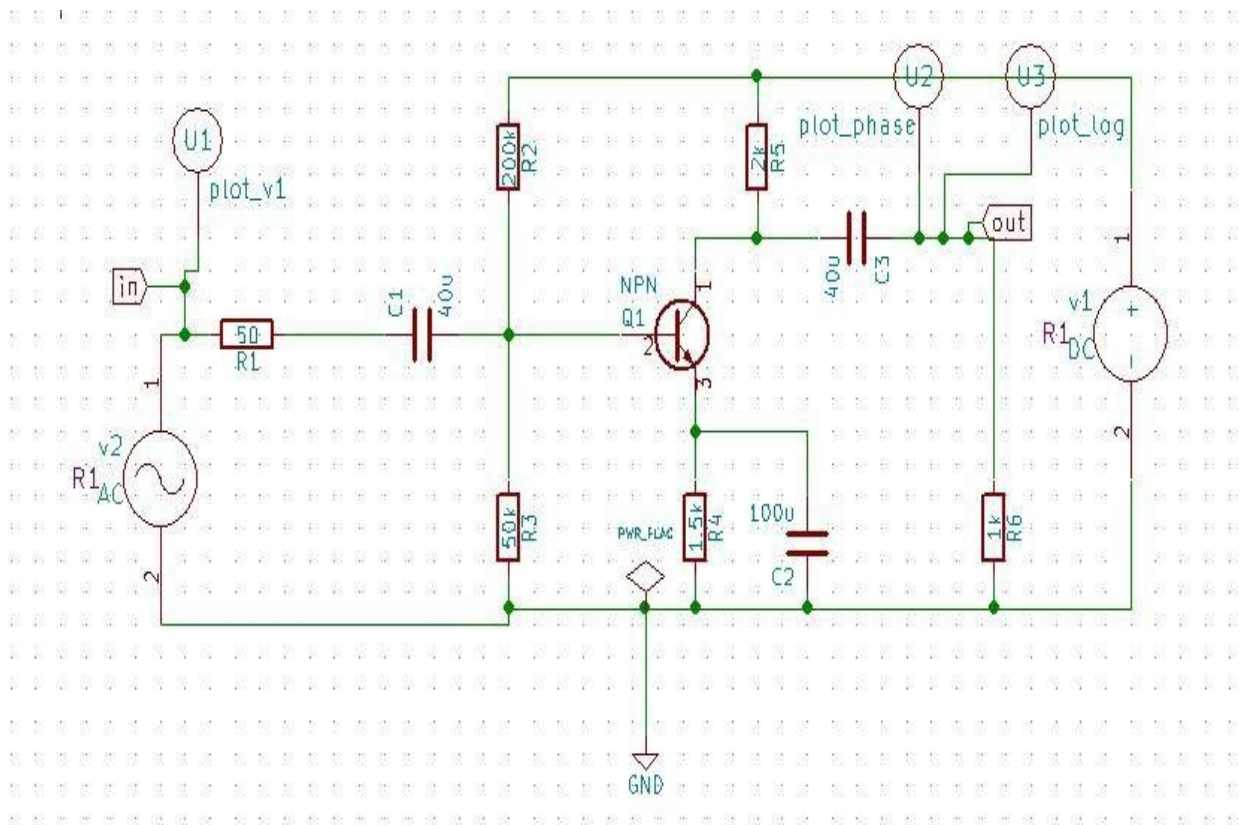

Figure 1: Frequency response of BJT

Simulation Results :

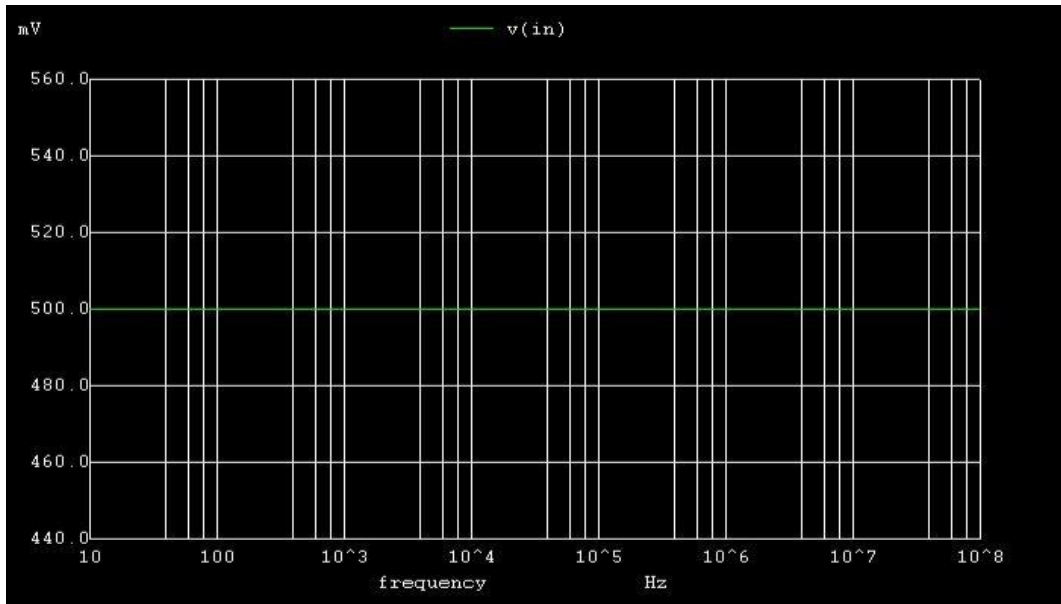

Figure 2: Ngspice Input Plot

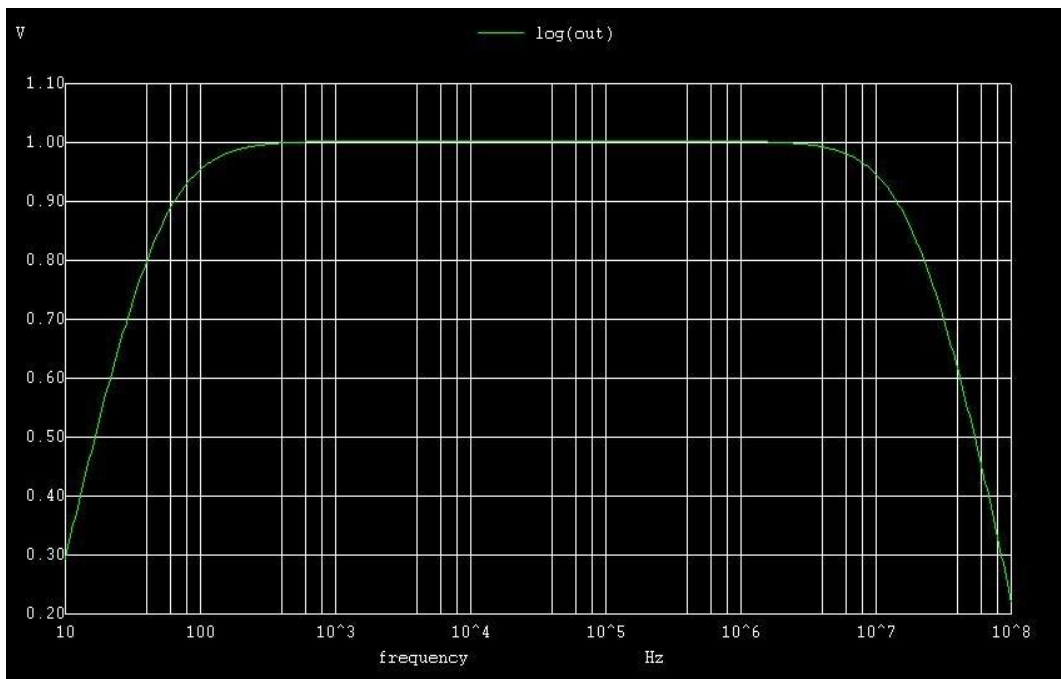

Figure 3: Ngspice Output Frequency Plot

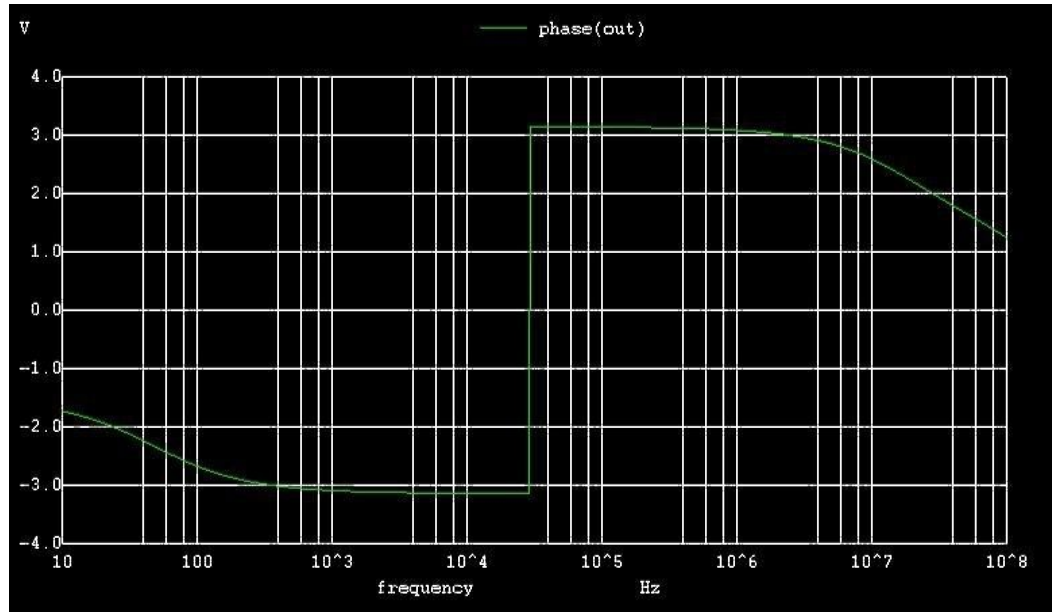

Figure 4: Ngspice Output Phase Plot

Conclusion :

Thus, we have studied the frequency response of the BJT amplifier using eSim and we get the appropriate waveforms.

References :

<http://www.electronics-tutorials.ws/amplifier/frequency-response.html>